



REV		DATE	RELEASED REVISION	DWN
A		01/01/2009	RELEASED	-
-		-	-	-
-		-	-	-

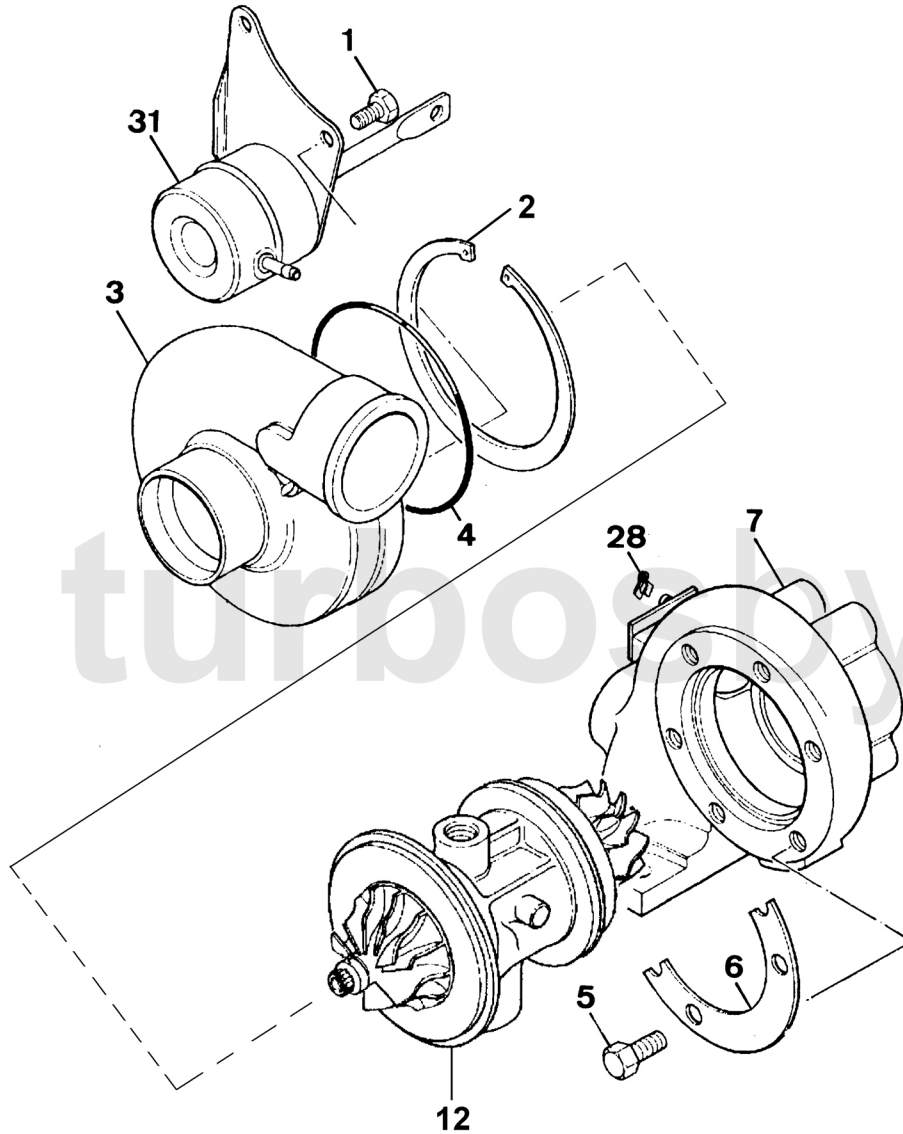
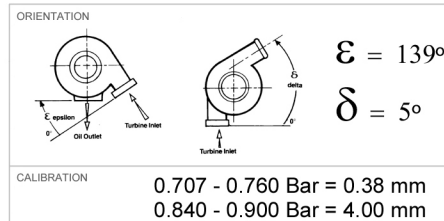

Fig	Description	Part number
1	Bolt x 2	400724-0610
2	Retaining ring	400589-0375
3	Compressor housing	444319-0016
4	O-ring	403069-0164
5	Bolt x 6	400788-0816
6	Clamp x 2	449028-0001
7	Turbine housing	430609-0203
12	C.H.R.A.	835995-5001S
28	Retainig ring	400702-0018
31	Actuator	700187-0001
195	Bracket (water pipe)	467560-0001
198	Bolt x 2 (br. water pipe)	400724-0610

Note: Illustration for reference only, may not resemble actual part.



TITLE		GT2554R	
SIZE	PART NO.	REV	
A	836023-5001S	A	
DRAWN:	DATE:	CHECKED:	SHEET: 1 OF 1
ACS	29/09/2015		