

REV		DATE	RELEASED REVISION	DWN
A		01/11/2014	RELEASED	-
-	-	-	-	-
-	-	-	-	-

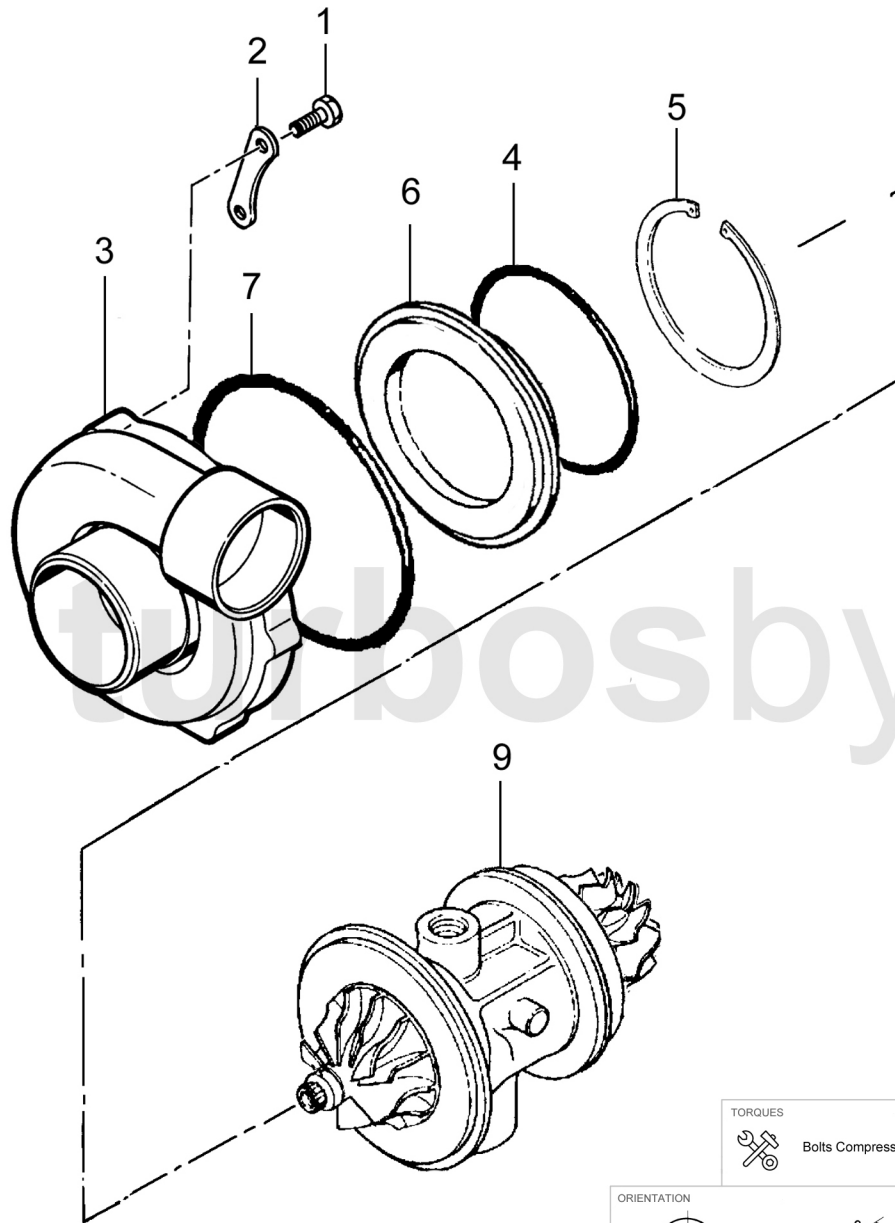
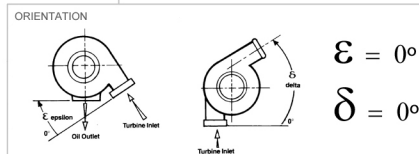

Fig	Description	Part number
1	Bolt x 6	400572-0300
2	Clamp x 2	443136-0001
3	Compressor housing	467927-0041
4	O-ring	403069-0164
5	Retaining ring	400589-0375
6	Adapter	448420-0002
7	O ring	403069-0077
9	C.H.R.A.	836000-5002S

Note: Illustration for reference only, may not resemble actual part.

TORQUES  
 Bolts Compressor housing : 16.4 - 18.6 Nm



CALIBRATION  
 Free float



TITLE		GT3071R	
SIZE	PART NO.	REV	
A	836028-5001S	B	
DRAWN:	DATE:	CHECKED:	SHEET: 1 OF 1
ACS	21/04/2015		