



REV	DATE	RELEASED REVISION	DWN
A	01/07/2013	RELEASED	-
-	-	-	-
-	-	-	-

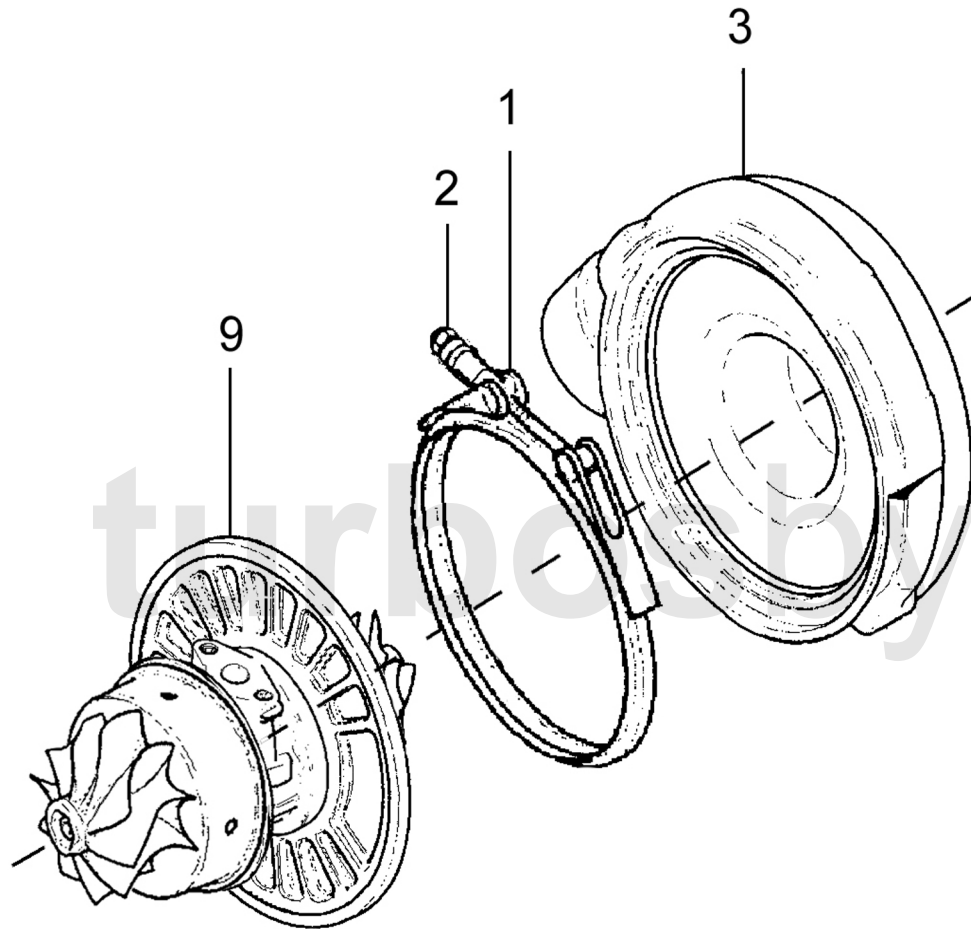
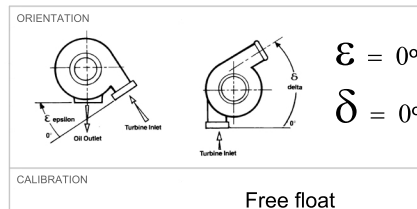

Fig	Description	Part number
1	V clamp	446401-0690
2	Nut	400515-0212
3	Compressor housing	886686-0002
-	O-ring	403069-0069
9	C.H.R.A.	860779-5010S
-	Speed sensor bolt	400674-0516
-	Plug	871104-0001
-	O-ring (plug)	403069-0242
-	Water fitting x 2	872902-0001
-	Washer (water fitting) x 2	444657-0006
-	Plug (air conection)	400809-0203



Note: Illustration for reference only, may not resemble actual part.



TITLE		<b>G40-1150</b>	
SIZE	PART NO.	REV	
A	860777-5002S	A	
DRAWN:	DATE:	CHECKED:	SHEET: 1 OF 1
ACS	20/08/2022		